

LONGboard⁶¹

61-key Professional Performance Instrument

SHORTboard⁴⁹

49-key Professional Performance Instrument



LONGboard⁶¹

SHORTboard⁴⁹

User's Guide

© 2010 E-MU Systems

All Rights Reserved

Version: B

E-MU World Headquarters

E-MU Systems

1500 Green Hills Road
Scotts Valley, CA 95066
USA

Europe

Creative Labs (Ireland) Ltd.

Ballycoolin Business Park
Blanchardstown Dublin 15
IRELAND

Japan

Creative Media K.K.

Kanda Eight Bldg. 3F
4-6-7 Soto-Kanda
Chiyoda-ku, Tokyo 101-0021
JAPAN

Contents

Introduction	3
Features:	4
What is included?	4
Start Playing	5
Powering Up	6
Standalone Operation	6
USB Powered Operation	6
Basic Hardware Connections.	7
MIDI Routing	8
MIDI Path when a Computer is Connected via USB	8
MIDI Path when a Computer is NOT Connected.	9
Wireless Audio Connection with E-MU PIPELine	10
Setting Up Your Computer for MIDI	13
Front Panel Controls	14
Program Selection	14
Banks and Groups	14

Rear Panel	23
Control and Power	23
Digital Connections	25
Appendix	28
Troubleshooting	28
E-MU Keys Program Chart	30
General MIDI Program Chart	31
General MIDI - Channel 10 Percussion	33
General MIDI Drum Map	34
Specifications	35
Safety Information	36
Regulatory Information	37
Notice for the USA	37
California Proposition 65 Statement	38
WEEE Directive 2006/66/EC	39
WEEE Directive 2002/96/EC	40

INTRODUCTION



Congratulations on your purchase of the E-MU LONGboard 61 or SHORTboard 49. You've just purchased an outstanding MIDI controller keyboard united with a 16-part multitimbral, 128-voice professional sample-based instrument and a custom 64MB sound set.

LONGboard 61 or SHORTboard 49 are professional USB/MIDI instrument with unmatched playability, real-time control and programmability in portable 49 key, and 61 key packages.

The LONGboard 61 features a 61-note premium semi-weighted keyboard, while the SHORTboard 49 features a compact 49-note semi-weighted keyboard. Both models feature full-size velocity-sensitive keys with after-touch, pitch and modulation wheels, and 6 controller knobs.

The keyboards are ideal for either studio or stage use, since they can be used as stand-alone MIDI controllers, or with a USB equipped PC or Macintosh computer. The MIDI input and output can also serve as a computer MIDI interface when connected via USB.

As an added bonus, the LONGboard 61 and SHORTboard 49 contain a built-in wireless audio transmitter, which links to the E-MU PIPELINE receiver giving you a 49 foot (15 meter) range of wireless freedom.

Now, read on to learn all about your new favorite keyboard.

Features:

- Velocity sensitivity and channel aftertouch
- 128-voice polyphony
- 16-part multitimbral synthesizer
- 64 MB sound bank with 64 custom E-MU Keys programs and 128 General MIDI (GM) compatible programs
- Built-in wireless E-MU PIPEline transmitter
- Synthesizer controller knobs (*double as MIDI controllers*)
- Reverb and Chorus effects
- User-definable split keyboard (*for playing two sounds at once*)
- Pitch and Mod Wheels
- Octave transpose buttons
- MIDI Input and Output jacks
(*the MIDI jacks can also function as a MIDI interface for your computer*)
- Dual 1/4" headphone jacks
- Can be powered via DC adapter, USB bus power, or batteries

What is included?

- LONGboard ⁶¹ or SHORTboard ⁴⁹
- 5V DC Power Supply
- USB Cable
- Quick Start Manual
- Read-me file

START PLAYING

Your keyboard has been designed to be easy to use. Simply connect the power supply, connect headphones or your mixer/sound system, turn it on and start playing.



Two sets of stereo headphones can be connected.

Power Switch

Power to the keyboard is controlled using a three-position slide switch.

DC 5V USB
BATTERY OFF POWER



- Center** - - - - - Turns the keyboard Off
- USB Power** - - - Use when connected to your computer via USB
- DC 5V/Battery** - Use when not connected to the computer. The keyboard can be powered via the 5V DC adapter or (6) D batteries. *(Please refer to the following page.)*

Note: The 5V DC Adapter takes precedence if batteries are installed and DC power is applied.

POWERING UP

Standalone Operation

The keyboard can be powered using any of the following methods:

- Via USB when connected to a computer
- The included 5V @ 500mA power supply
- With a USB type power supply (*not included*)
- (6) D-size batteries

USB Powered Operation

The keyboard can receive power through the USB cable when connected to a PC or Mac. The USB connection can also transmit and receive MIDI data to and from the computer. **Audio is not transmitted or received over USB.**

Important: Always connect to the USB jack on the computer itself and NOT to a low-power USB connection that may be present on your computer keyboard or other USB peripheral.

- **TIP:** If the keyboard doesn't work when powered via USB, try disconnecting the USB cable and using the AC adapter for power.
(*Your computer may not be supplying enough power through the USB port.*)

Battery Installation

The battery compartment is located on the bottom panel of the unit. Press the two tabs to open. Install the batteries as labelled on the bottom of the battery compartment with the + aligned with the + side of the batteries.



BASIC HARDWARE CONNECTIONS

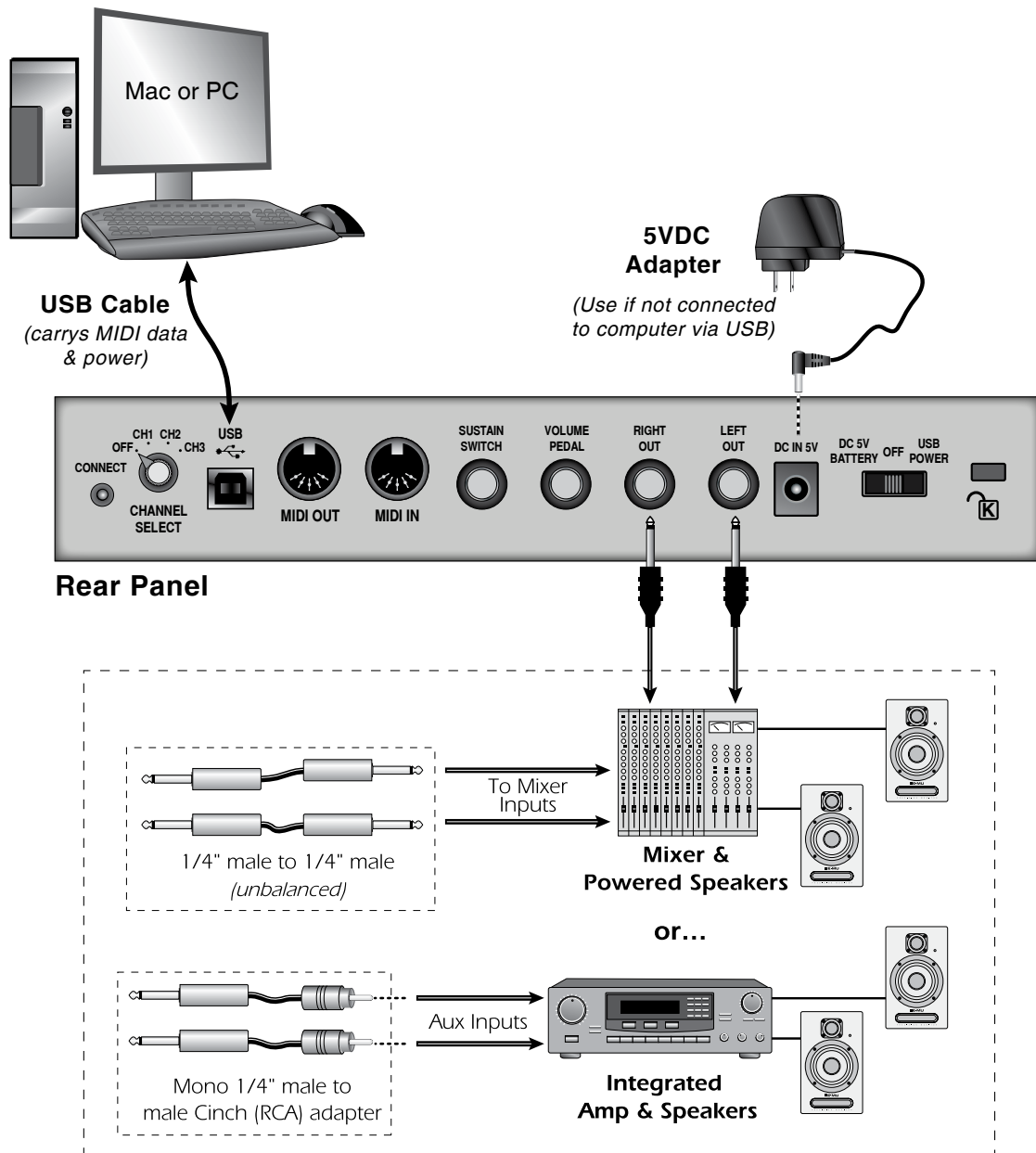

- Connect the audio outputs to an audio mixer or integrated amp and speakers (such as your home stereo).
- The USB cable carries MIDI data and power. This connection allows you to record and play back your keyboard performance using a MIDI sequencer and your computer. The keyboard can also be powered via USB.

MIDI ROUTING

LONGboard and SHORTboard automatically switch their MIDI connections when a computer is connected to the USB port.

With a computer connected there are two MIDI ports (*USB Audio Devices 1 & 2*) available on your computer. The keyboard connects to Port 1 Out and the internal sound engine. Port 1 In from the computer can also control the internal sound engine.

Port 2 (*USB Audio Device 2*) connects directly to the MIDI input and output jacks functioning as a computer MIDI interface.

MIDI Path when a Computer is Connected via USB

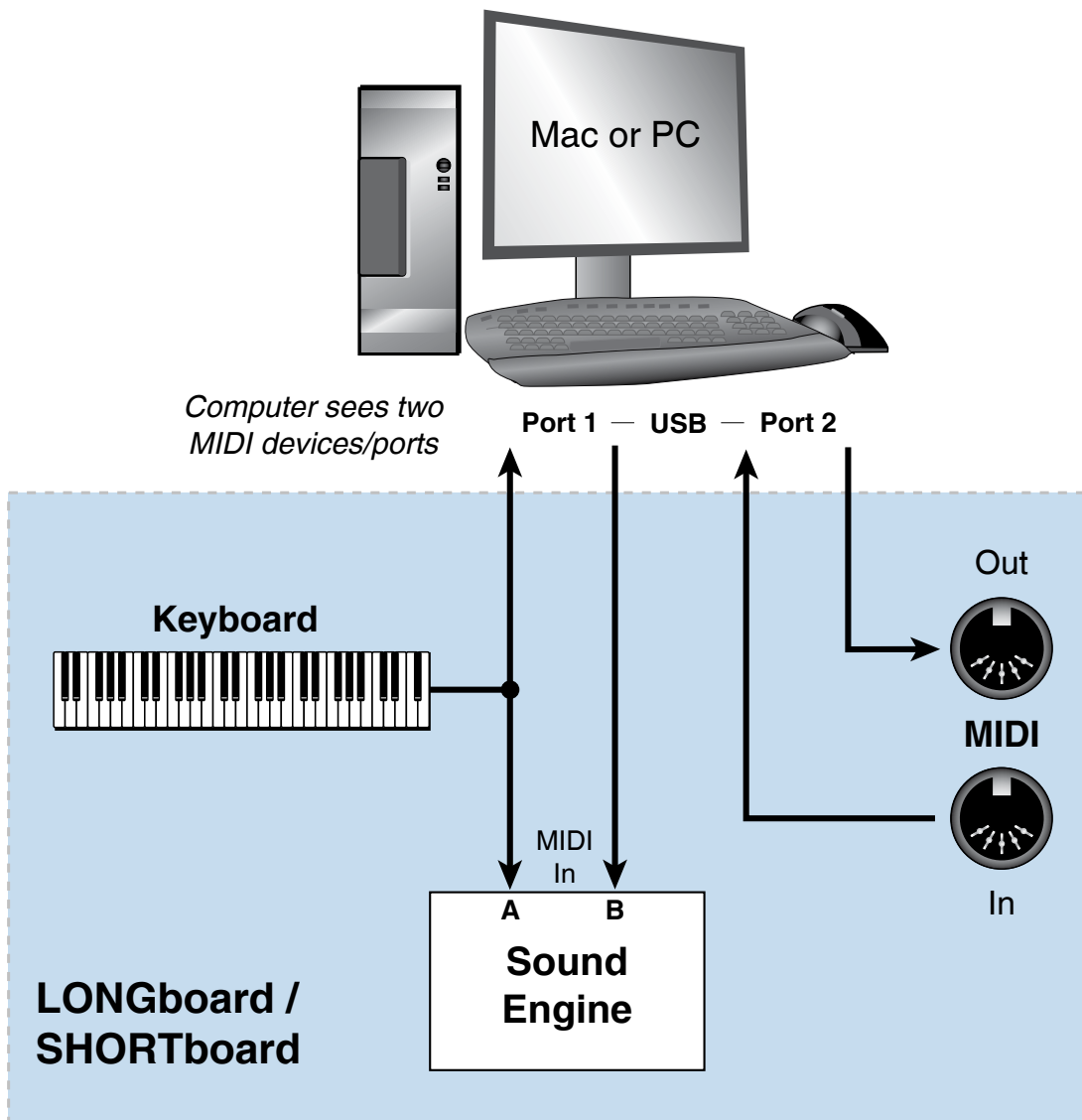

MIDI Path when a Computer is NOT Connected

With no computer connected to USB, the keyboard connects to MIDI Out and the internal sound engine.

MIDI In connects to the internal sound engine.

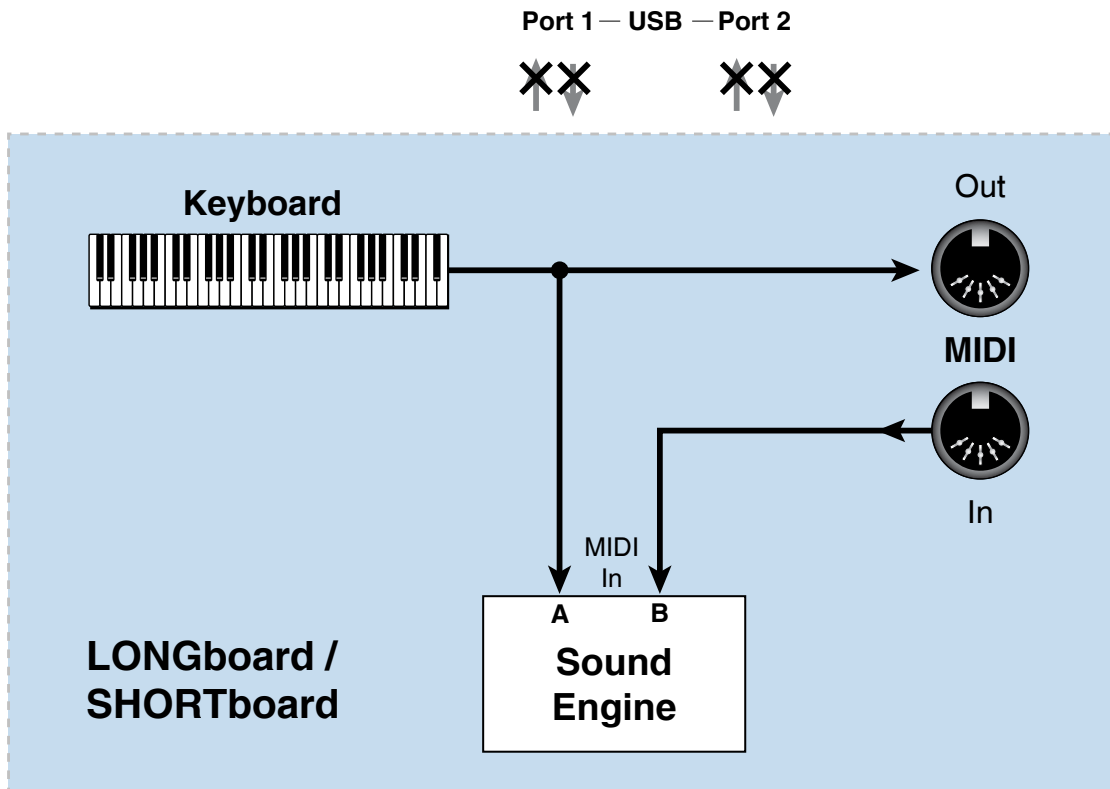

WIRELESS AUDIO CONNECTION WITH E-MU PIPELINE

PIPELine

LONGboard and SHORTboard have a built-in wireless audio transmitter compatible with the E-MU PIPELine wireless stereo audio transmitter/receiver system. The keyboard's transmitter operates in "paired" mode by default. Paired mode allows you to link your keyboard with one (and only one) PIPELine. Here's how to link your keyboard to a PIPELine in Paired mode. Paired and Broadcast modes will be described later.

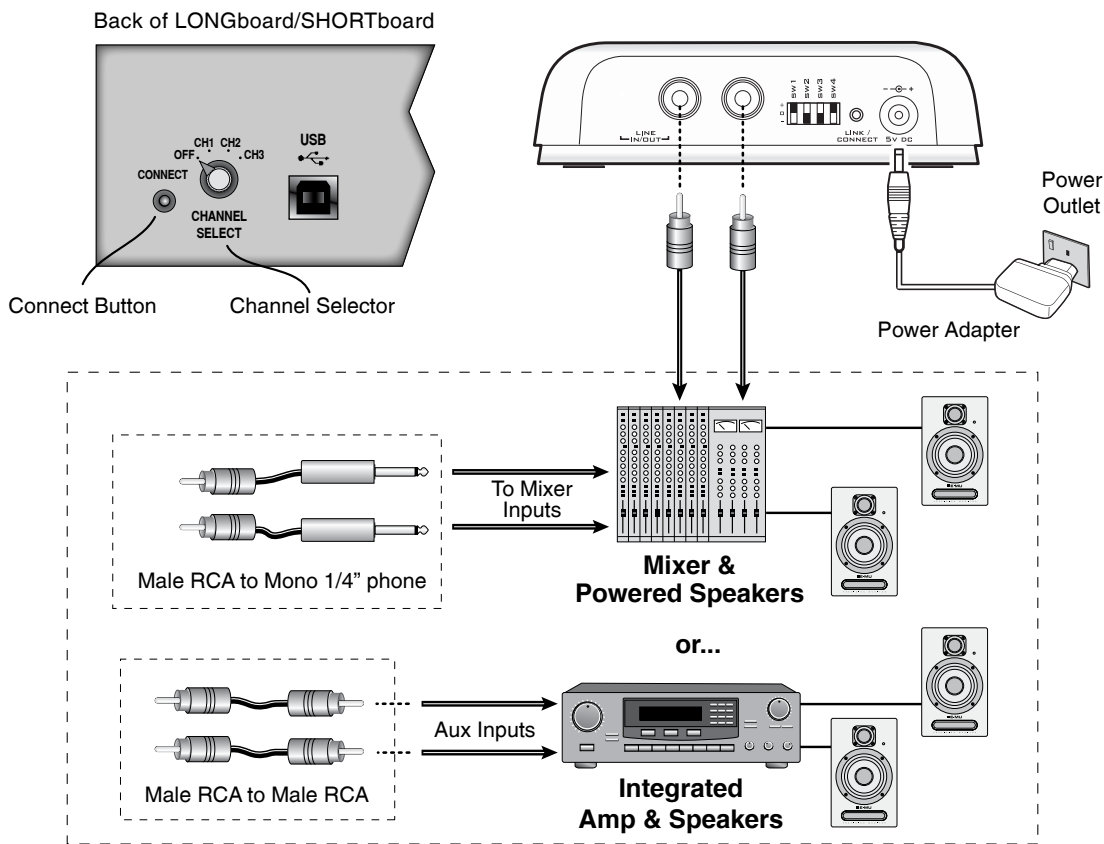

Connect the Audio

- Set up the PIPELine audio outputs to headphones; an audio mixer; or integrated amp and speakers.

On the Rear Panel of the Keyboard

- Use the **Channel Select Knob** to set the Channel Number.

On the PIPELine Receiver

1. Set the **CH** switch to Ch1, Ch2, or Ch3 to match the keyboard Channel Selector.

-
2. Set the **B/P** switch to the (+) position (Paired mode).
 3. Set the **R/T** switch to the (-) position (Receive).
 4. Set the **D/A** switch to the (+) position (Analog).
(*LONGboard and SHORTboard don't support digital mode.*)

Link Procedure

On the Rear Panel of your Keyboard

5. Press the **Connect** button.

On the PIPEline

6. Press the **Link/Connect** button. The white LED will stop flashing when connected.
 7. **Play the keyboard.** You will hear audio from the PIPEline!
- If you change channels, the keyboard and PIPEline will automatically re-link. (Of course, the keyboard and PIPEline channels must match!)
 - If you turn off the keyboard, PIPEline, or both; they will automatically re-link when you turn them back on.
 - You only have to perform the Link procedure again if you decide to link to a different PIPEline, or if you decide to change Paired/Broadcasting modes.

Selecting Paired and Broadcasting Modes

The keyboard's wireless transmitter operates in "paired" mode by default. Paired mode allows you to link your keyboard with one (and only one) PIPEline. Broadcasting Mode allows you to link your keyboard to one or more PIPElines. Please refer to the PIPEline User's Guide for a detailed description of these modes. The PIPEline User's Guide is available at the E-MU web site: www.emu.com.

► **To Switch between Paired and Broadcasting modes:**

1. **Important:** First set the keyboard **Channel Select** knob to **OFF**.
2. **To select Broadcasting mode,** blip* the Keyboard Link button 7 times.
3. **To select Paired mode,** blip* the Keyboard Link button 3 times.

* A "blip" is a quick press/release of the button.

Linking in Broadcasting Mode

Here's how to link your Keyboard to one or more PIPELines in Broadcasting mode.

1. Turn on your Keyboard. Turn on your PIPELine(s), the white LED will blink.

Setup Procedure

Connect the Audio

- Set up the PIPELine audio outputs to headphones; an audio mixer; or integrated amp and speakers.

On the Rear Panel of your Keyboard

- Use the Channel Select Knob to set the Channel Number.

On each PIPELine

2. Set the CH switch to Ch1, Ch2, or Ch3 to match the Keyboard Channel Selector.
3. Set the B/P switch to the (-) position (Broadcasting mode).
4. Set the R/T switch to the (-) position (Receive).
5. Set the D/A switch to the (+) position (Analog).

Link Procedure

On the Rear Panel of your Keyboard

- Press the Connect button.

On each PIPELine

6. Press the Link/Connect button. The white LED will stop flashing when connected.
 7. Repeat the Link Procedure for each PIPELine.
 8. Play your Keyboard. You will hear audio from each PIPELine linked to your Keyboard.
- If you change channels, the Keyboard and PIPELine will automatically re-link. (Of course, the Keyboard and PIPELine channels must match!)
 - If you turn off the Keyboard, PIPELine, or both; they will automatically re-link when you turn them back on.
 - You only have to perform the Link procedure again if you decide to link to a different PIPELine, or if you change Paired/Broadcast modes.

SETTING UP YOUR COMPUTER FOR MIDI

The USB cable functions as a bidirectional MIDI cable, allowing you to record and playback your performance using MIDI sequencing software (not included).

MIDI is a protocol consisting of data messages that are used to control synthesizers, sound modules, keyboards, or software “virtual instruments.” MIDI messages contain instructions such as what note to play, when to play it, and which sound to play.

When connected to your computer via USB, the Keyboard MIDI ports will appear in the “MIDI Devices” (Mac) or “Sounds and Audio Devices” (PC), indicating that a valid connection has been made. Refer to your MIDI sequencing software manual to learn how to record and play back MIDI sequences.

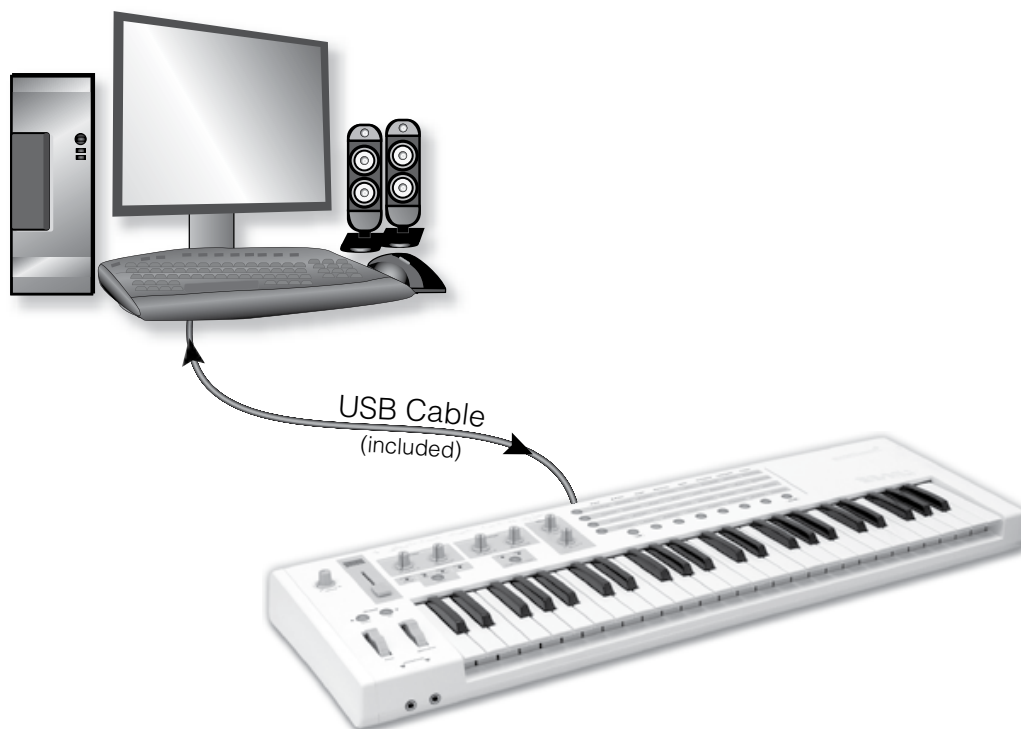

The USB cable functions as a bidirectional MIDI cable. The MIDI Input allows you to use other MIDI controllers such as another keyboard, extra knobs or drum pads.

The MIDI Output sends data from the keyboard, wheels and knobs.

The MIDI Input and Output jacks also function as a MIDI interface, allowing other MIDI devices to be connected to your computer.

FRONT PANEL CONTROLS

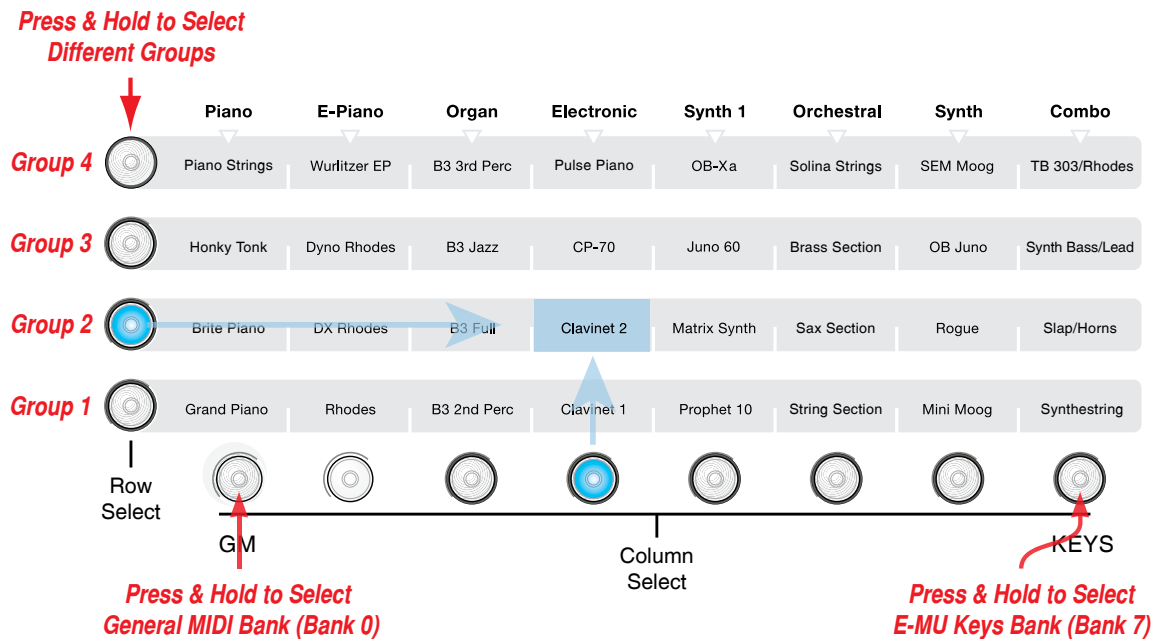

Program Selection

Each *Program* contains a different sound. To Select a **Program**, press a row and/or a column button. The program at the intersection of the column and row buttons is selected and the selected program number flashes in the display (1-128).

Note: The program names on the front panel refer to Bank 7, Group 1.

Banks and Groups

A **Bank** may contain up to 128 programs, arranged in 4 **Groups** of 32 programs.

To Select Another Group: Press and Hold one of the **Row Select** buttons for 2 seconds to select another group of 32 programs. The LED above the slider flashes the selected Group number, i.e. **9P 2** (group 2).

To Select Another Bank: Press and Hold either the **Left** or **Right** column button for 2 seconds to switch between program banks 0 and 7 (and transmit a **MIDI Bank Select** message on CC00). Press and Hold the column button marked **KEYS** for 2 seconds to switch back to bank 7. The LED above the slider flashes the selected bank number, i.e. **bn 7**.

Bank 7, Group 2 Programs

Press and hold Group 2 button (when in E-MU Keys Bank)

Wurlly & CP	Wurlly & Solina	B3 888 3rd & All Out	TB303 & Clavinet	SEM	OB, Juno & B3	SEM, Moog & OBX	All Saws & Squares	
CP-70 & Rhodes	Dyno Piano & OB	B3 Jazz DX	All Saws	Mega Synth	OB & Saws	Prophet PWM	Pulse Keys	
Group 2 	CP-70 & Strings	DX & Rhodes	B3 All Out	Clavinet & Pulse	Juno & Rogue	Rogue & OBX	Fat Mini	Multi Bass
<i>Press & Hold</i>	CP, Strings & Dyno	Dyno & Strings	B3 888 2nd & Rhodes	Clavinet 1 & 2	Matrix & Solina	Solina & OBX	Moog Bass	Saw Bass

General MIDI Bank (128 General MIDI Programs)

See the [General MIDI Program Chart](#) for a numerical listing.

General MIDI, Group 1 Programs

Press and hold Group 1 button while in General MIDI Bank.

Nylon Guitar	Steel Guitar	Jazz Guitar	Clean Guitar	Guitar Mutes	Overdrive Guitar	Distortion Guitar	Guitar Harmonics	
Organ 1	Organ 2	Organ 3	Church Organ	Reed Organ	Accordian	Harmonica	Bandoneon	
Celesta	Glockenspiel	Music Box	Vibraphone	Marimba	Xylophone	Tubular Bells	Dulcimer	
Group 1 	Piano 1	Piano 2	Piano 3	Honky Tonk	Electric Piano 1	Electric Piano 2	Harpichord	Clavinet
<i>Press & Hold</i>								

General MIDI, Group 2 Programs

Press and hold Group 2 button while in General MIDI Bank.

Trumpet	Trombone	Tuba	Mute Trumpet	French Horns	Brass	Synth Brass 1	Synth Brass 2	
Strings	Slow Strings	Synth Strings 1	Synth Strings 2	Choir Ahhs	Voice Oohs	Synth Vox	Orchestra Hit	
Group 2 	Violin	Viola	Cello	Contrabass	Tremolo Strings	Pizzacato	Harp	Timpani
<i>Press & Hold</i>	Acoustic Bass	Fingered Bass	Picked Bass	Fretless Bass	Slap Bass 1	Slap Bass 2	Synth Bass 1	Synth Bass 2

General MIDI, Group 3 Programs

Press and hold Group 3 button while in General MIDI Bank.

Group 3



Press & Hold

Fantasia	Warm Pad	Poly Synth	Space Voice	Bowed Glass	Metal Pad	Halo Pad	Sweep Pad
Square Wave	Saw Wave	Synth Calliope	Chiffer Lead	Charang	Solo Vox	5th Square Wave	Bass & Lead
Piccolo	Flute	Recorder	Pan Flute	Bottle Chiff	Shakuhachi	Whistle	Ocarina
Soprano Sax	Alto Sax	Tenor Sax	Baritone Sax	Oboe	English Horn	Bassoon	Clarinet

General MIDI, Group 4 Programs

Press and hold Group 4 button while in General MIDI Bank.

Group 4



Press & Hold

Fret Noise	Breath Noize	Seashore	Bird	Telephone	Helicopter	Applause	Gun Shot
Tinker Bell	Agogo	Steel Drum	Wood Block	Taiko Drum	Melodic Tom	Synth Drum	Reverse Cymbal
Sitar	Banjo	Shamisen	Koto	Kalimba	Bagpipe	Fiddle	Shenai
Ice Rain	Soundtrack	Crystal	Atmosphere	Brightness	Goblin	Echo Drops	Star Therme

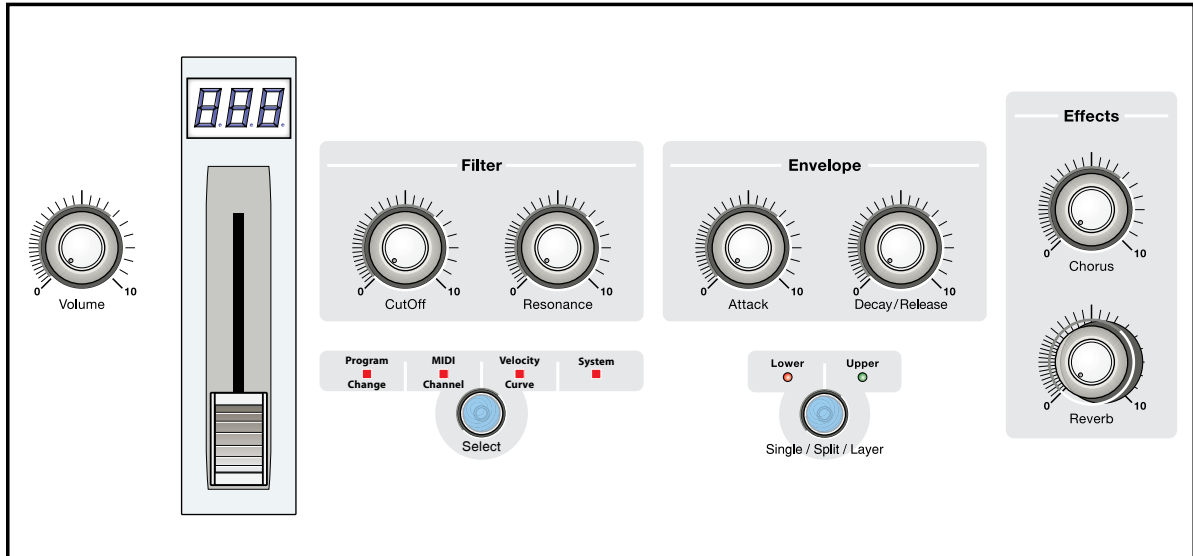

Data Slider & Numeric Display

This control is used to enter values while editing and as a performance controller while playing. You can change the function of this control by changing the **CC Assign** number.

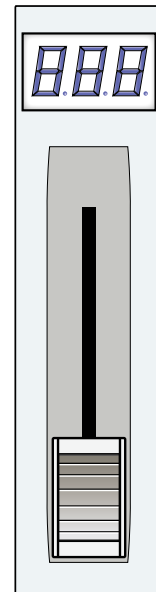

Octave Buttons

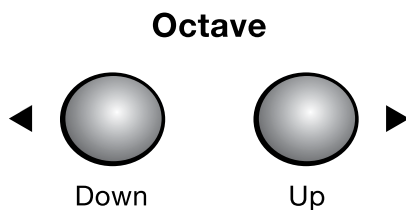

The octave buttons transpose the keyboard up or down one octave. When the transpose buttons are pressed, the octave transpose amount appears in the numeric display, i.e. -2 .

- Whenever the data slider is used for editing, the octave buttons function as increment/decrement buttons, allowing you to change values one unit at a time.
- Pressing both octave buttons simultaneously turns off any “stuck notes” and clears all controllers, functioning as a MIDI Panic Button. The display flashes, PA_n .
- In split mode, the octave buttons control the currently selected range of the keyboard.

Single/Split/Layer Button

The keyboard can be “split” at any note to play one program on the lower section and a completely different programs on the upper section. Two sounds can also be “layered” over the entire keyboard.

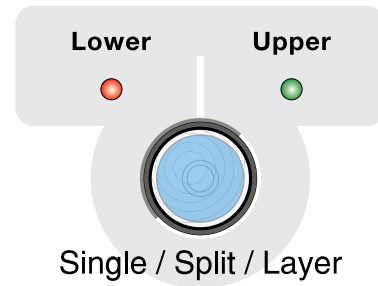

► **To Set the Keyboard Split Point:**

Press and Hold the Split button and press a keyboard key to split the keyboard at a specific key.

► **Split Mode:**

Press the Split button again to switch between upper and lower sections or both (Layer mode). When Split mode is active, the front panel knobs, slider, octave buttons, program select buttons, wheels, and pedal all affect whichever keyboard section is currently selected.

With the Lower LED on, change the lower program, edit a synth control to edit the lower program, or change the MIDI channel for the lower section.

Select “Upper” then change the upper program, edit a synth control on the upper program, or change the MIDI channel for the upper section.

► **Layer Mode:**

When the Upper and Lower LEDs are both lit, *Layer Mode* is in effect and both the upper and lower programs will be heard when you play the keyboard.

Changing a program when in Layer mode will change the “Upper” program. The settings of the Lower program remain in effect when you go back to Normal mode.

When in Layer mode, the Data Slider functions as a balance control between the upper and lower layers.

Note: Splits and Layers cannot be saved with the program. The Split Point, however, is retained in memory until you power off the keyboard.

Synthesizer Controls

These four controls allow you to modify the selected program. Turning a knob sets the parameter to the current knob position. Select the program again to restore the original setting.

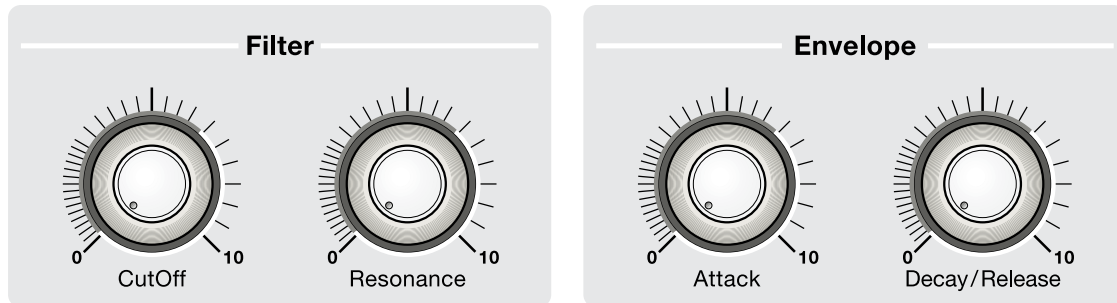

Cutoff - Controls the low pass filter cutoff frequency. Turning the control up allows more high frequencies to pass. Turning the control down reduces high frequencies.

Resonance - Resonance or “Q” boosts the frequencies around the cutoff frequency. This gives the filter a sharper and more synthesizer-like sound.

Attack - When a key is pressed, the low pass filter cutoff is turned up at a rate specified by this control (if edited). Turning the control up increases the attack time.

Decay/Release - This control specifies the time it takes for the low pass filter to close down after a key is released (and depending on the selected program, after the attack time).

Effects Controls

The Chorus and Reverb effects are applied to all programs and to both sides of a split keyboard.

Chorus - This effect thickens the sound as it makes one voice sound like many. The knob controls the chorus depth or “how much” chorus is applied.

Reverb - Reverberation is a simulation of a natural space such as a room or hall. This knob controls the reverb amount.

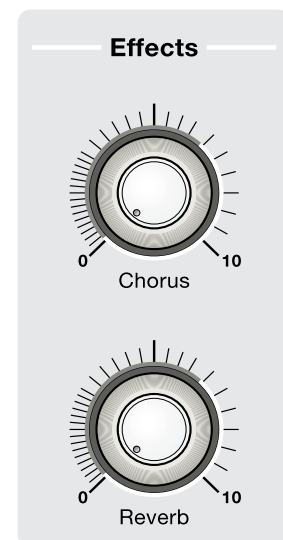

Saving Your Control Settings

The settings of the six control knobs can be saved with the program allowing you to customize the sound set. **Note:** Only programs in the KEYS bank can be saved with modifications. General MIDI programs cannot be saved.

1. Set the controls the way you want them.
2. Press and hold the Select button, then press the Column button of the current program. **Sto** appears in the display indicating that your custom settings have been stored with the program.

► **To Restore the Factory Knob Settings:**

1. To restore all factory defaults, hold the select button and power on.

Select Button

Press this button to cycle through the editing options, then adjust the value using the data slider.

These settings affect all programs and are automatically stored.

While in edit mode (*any of the Select LEDs on*), programs cannot be selected.

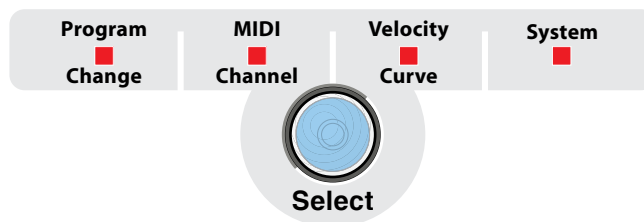

Program

This option allows you to access all 128 program change commands on the internal synthesizer or an external MIDI synthesizer.

► **To Select a Program using the Data Slider:**

1. Press the Select button repeatedly until the Program LED is lit.
2. Select the desired program number using the data slider.
3. The program change command is transmitted a second after you stop moving the data slider.

System Menu

MIDI CC - Allows you to assign MIDI Continuous Controller numbers to the data slider so it can be used as a performance control. After selecting a CC channel, the slider will send data to the internal synthesizer *as well as* sending MIDI CC data messages to an external MIDI synth or computer application.

You can control these internal synthesizer parameters using the data slider.

Parameter	MIDI Controller No.
Pan	10
Release (<i>only</i>)	72
Decay (<i>only</i>)	75
Global Aftertouch On/Off	85
Local Control On/Off	122

► **To Control Pan using the Data Slider:**

1. Press the **Select** button until **CC Assign** is selected.
2. Use the **Data Slider** to select the MIDI controller number: **10** (Pan).
3. Press the **Select** button repeatedly until none of the select LEDs are lit.
4. Move the **Data Slider** to adjust the **Pan** position.

MIDI Chn

Allows you to set the MIDI channel for the keyboard. Keyboard and controller data will be transmitted on this channel.

If *Split Mode* is selected, the MIDI channel will be set for the currently selected section (upper or lower). The upper and lower sections can each transmit on a different MIDI channel. (*In either Split or Layer mode.*)

► **To Select a MIDI Channel:**

1. Press the **Select** button repeatedly until the **MIDI Chn** LED is lit.
2. **Select the desired MIDI Channel** using the data slider.
3. Press **Select** to exit the menu.

Velo Curve

Selects 1 of the 8 velocity curves to customize the feel of the keyboard. When playing a velocity-sensitive sound (such as a piano), select a curve that provides the most natural response to your playing style.

The selected velocity curve modifies the MIDI velocity data from the keyboard to MIDI Out and the internal sound engine. It does NOT modify incoming MIDI data.

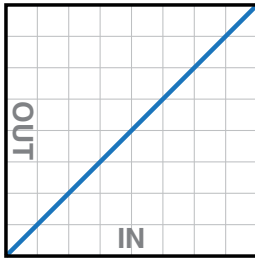

1 - Linear: No change to velocity

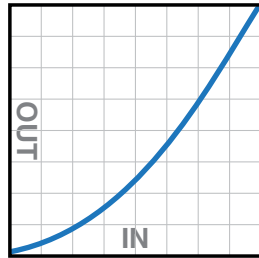

2 - Compressed: For hard players

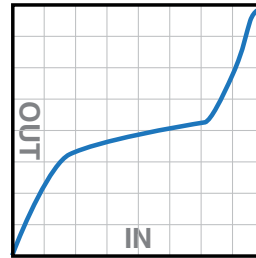

3 - Medium Velocity: Compressed dynamics

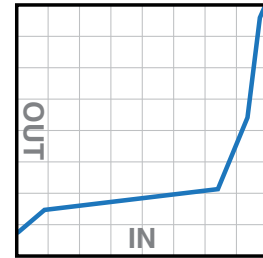

4 - Compressor/Expander: Low Values, then high

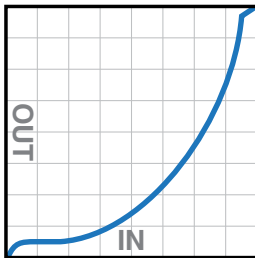

5 - Low Velo 1: Extreme compression: Low values

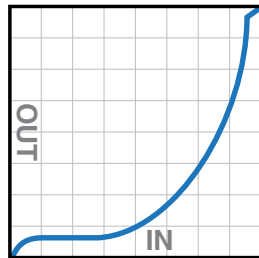

6 - Low Velo 2: Extreme compression: Low values

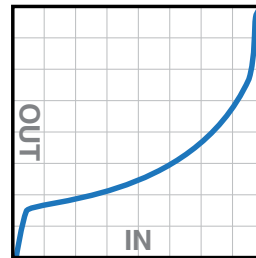

7 - Compressed: Top and bottom ends cut

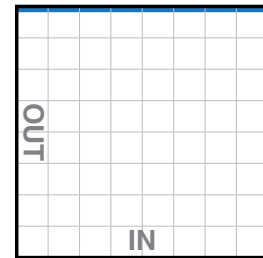

8 - Full Velocity: Only outputs full velocity

Volume Control

This analog volume control adjusts the output volume for the main outputs and both headphone outputs. It does not control MIDI volume or volume to the wireless transmitter. To control volume to the PIPEline transmitter, use the data slider set to controller #7.

Pitch & Mod Wheels

The pitch wheel is a spring-loaded controller for bending the pitch of notes during performance.

The “mod” or modulation wheel usually controls the amount of vibrato (LFO to pitch) during performance. The mod wheel also transmits on MIDI CC 01.

Note: The mod wheel controls tremolo (LFO to volume) instead of vibrato in some bank 7 programs.

REAR PANEL

Control and Power

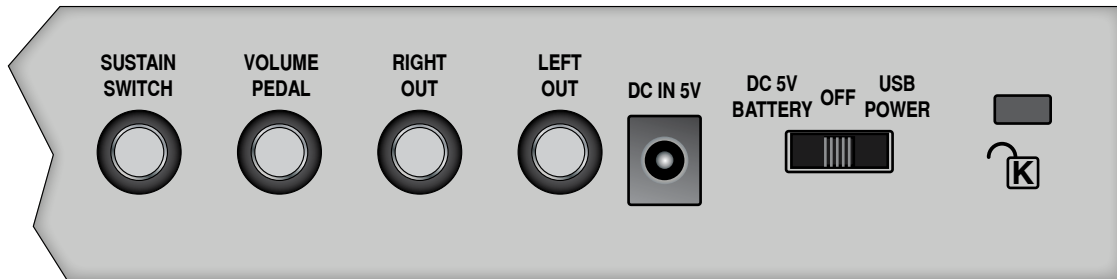

DC Power Input

Connect the supplied 5VDC @500mA power supply to this connector. You don't need to use the 5VDC supply if the keyboard is connected via USB to your computer, or if running on battery power.

Power Switch

Power to the keyboard is controlled using a three-position slide switch.

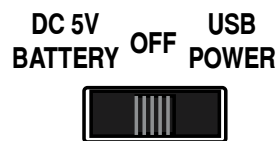

Center - - - - - Keyboard is Off

USB Power - - - Keyboard is powered via USB power

DC 5V/Battery - Keyboard is powered via 5V DC Adapter or Batteries

Note: The 5V DC Adapter takes precedence if batteries are installed and DC power is applied.

Output Jacks

The stereo output jacks carry low-impedance, line level signals (+6dBV, unbalanced) designed to interface with most professional and consumer audio gear.

Sustain Footswitch

This jack accepts an on/off type footswitch to sustain held keys. Either a normally-open or normally-closed momentary footswitch can be used, as the polarity is automatically sensed on power-up.

Control Footpedal

This jack accepts a continuously variable footpedal to control the output volume. Most types of variable footpedals with a stereo plug can be used. *(Please refer to the wiring diagram shown below.)* You can also use a variable pedal that outputs 0-5 Volts DC at the tip of a mono phone plug.

Pedal Wiring Diagram

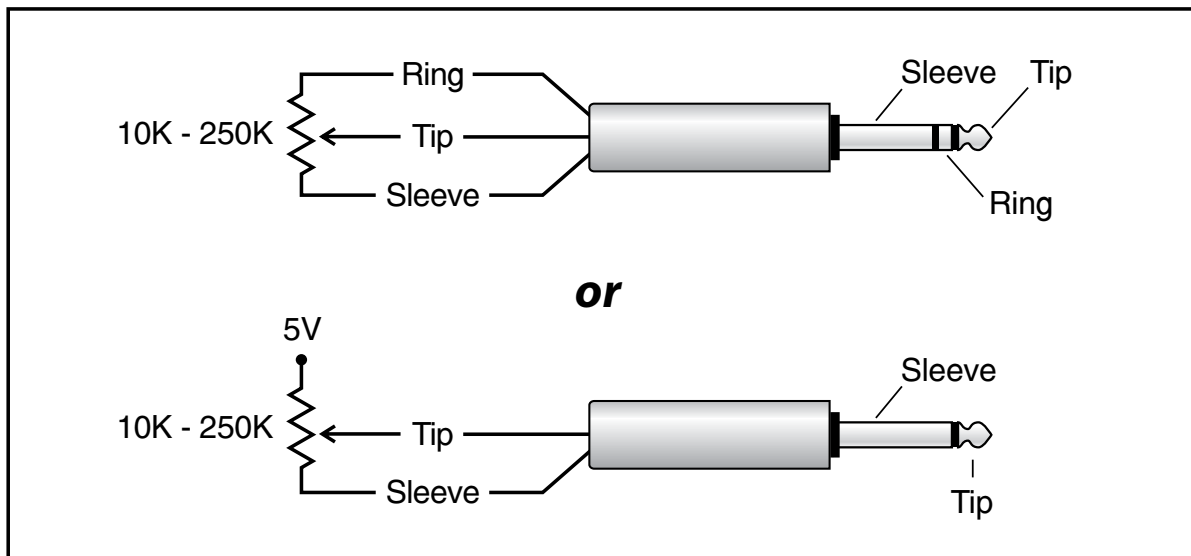

Kensington® Security Slot

You can secure your keyboard with a Kensington security cable to prevent it from being stolen.

Digital Connections

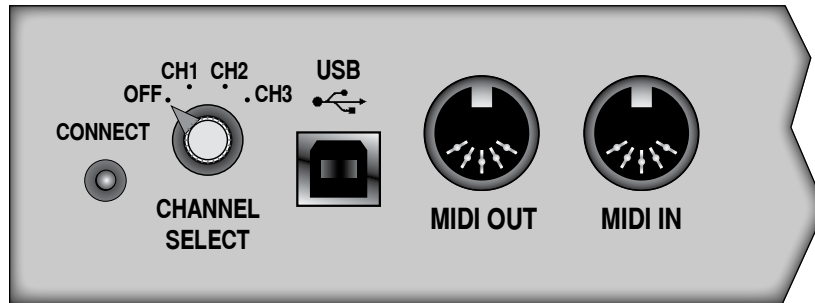

PIPEline Link Button & Channel Selector

These controls are used with the PIPEline wireless transceiver system. The keyboard functions as a transmitter only.

Setup: Set the channel number to match the channel set on the PIPEline receiver, then press the Link button. The Link button will flash until the two units are “paired.” The LED will now remain lit.

[See the Wireless Audio Connection instructions.](#)

USB Port

The USB Port is used to transmit MIDI data back and forth between the keyboard and your computer. The USB cable also supplies power to the unit. Therefore, the external power supply is not needed when a computer is connected via USB.

MIDI Connections

These connections provide a way to connect to other MIDI equipment to your system. MIDI Out can be used to transmit your keyboard performance to another MIDI instrument.

The keyboard can also be used as a MIDI interface for other MIDI gear when connected to your computer via USB.

Windows XP and Vista

LONGboard and SHORTboard are class-compliant devices and Windows will automatically detect and recognize them the first time you plug in the USB cable and turn the unit on. The keyboard will be listed as “USB Audio Device” in the *Windows XP Control Panel, Sounds & Audio Devices, Audio, MIDI Music Playback*. The MIDI interface section of the keyboard will be listed as “USB Audio Device [2].” The USB connection provides MIDI communication between the keyboard/MIDI interface and your computer, as well as power to the keyboard.

Optional E-MU MIDI drivers are available at www.emu.com.support. Installing the E-MU MIDI drivers will allow you to use the MIDI features of your keyboard with more than one application at the same time (multi-client). See the instructions on the E-MU web site for detailed information.

Mac OSX

Driver installation is not required with Macintosh OSX. However you will need to select the LONGboard or SHORTboard as a MIDI device in the Audio/MIDI Setup window of the Utilities menu before you can use it with other MIDI applications.

Set-up the MIDI Devices

1. Click Go -> Utilities from the menu bar.
2. Double-click Audio MIDI Setup, then click the MIDI Devices button if it's not already selected. The window shown below appears.



3. Click the **Add Device** button. A new external device icon like the one shown at right appears.

4. Double-click on the new external device if you want to set the MIDI Keyboard Properties. You have the option to name and change the icon for the device. Click **Apply**, then click the **Close** button to close the **Properties** window.



5. Connect the new external device to your MIDI Interface by dragging between the input and output connectors.

APPENDIX

Troubleshooting

Problem:

Sustain pedal operation is reversed (the notes sustain when the pedal isn't pressed and stop sustaining when the pedal is pressed).

Solution:

The sustain pedal polarity is sensed on power-up. Don't press the sustain pedal during power-up or the sustain pedal operation may be reversed.

Problem:

Interference from computer networking gear when using the PIPEline receiver.

Solution:

Try using a different channel on the keyboard and PIPEline.

Problem:

Noticeable delay in the sound when playing a software virtual instrument or when recording the keyboard's audio output.

Solution:

This delay is known as latency and can be adjusted by changing the buffer size setting in your recording application. Try to set the buffer size as low as possible without hearing clicks or pops in the audio stream. Faster computers generally allow smaller buffer size settings and lower latency.

Problem:

The keyboard is connected to my computer with the USB cable, but I cannot locate the LONGboard or SHORTboard USB keyboard in my software's MIDI devices dialog box.

Solution:

In Windows XP, your keyboard appears as a "USB Audio Device." Select "USB Audio Device" as your audio and MIDI input and output device.

We recommend going to www.emu.com to get our low latency E-MU MIDI drivers. This will enable the keyboard to be exposed in multiple applications at the same time.

Problem:

When the keyboard is connected to my Windows computer a question mark appears in the Windows Device Manager under *Other Devices > E-MU*. What is the problem?

Solution:

The question mark is normal. Your keyboard will function as a class-compliant device (i.e., without any drivers).

Problem:

When I play the keyboard or use any of the MIDI controls (wheel, knob, data slider, etc.), data is not transmitted from the MIDI Out jack.

Solution:

This may be caused by the MIDI Out being set to **Thru** Mode. The MIDI Out jack can be configured to transmit MIDI data from either the keyboard or from the MIDI In connector. If the MIDI Out mode is set to **Thru**, the keyboard and controls will not send any data to the MIDI Out jack.

E-MU Keys Program Chart

1	Grand Piano	33	CP-70 & String & Dyno
2	Rhodes Electric Piano	34	Dyno & Strings
3	B3 2nd Perc	35	B3 - 888 2nd & Rhodes
4	Clavinet 1	36	Clavinet 1 & 2
5	Prophet 10	37	Matrix & Solina
6	String Section	38	Solina & OBX
7	Mini Moog	39	Moog Bass
8	Synthesstring	40	Saw Bass
9	Brite Piano	41	CP-70 & Strings
10	DX Rhodes	42	DX & Rhodes
11	B3 Full	43	B3 - All Drawbars Out
12	Clavinet 2	44	Clavinet & Pulse
13	Matrix Synth	45	Juno-Rogue Layer
14	Sax Section	46	Rogue-OBX Layer
15	Moog Rogue	47	Fat Mini
16	Slap/Horns	48	Multi Bass
17	Honky Tonk	49	CP-70 & Rhodes
18	Dyno Rhodes	50	Dyno Piano & OBX
19	B3 Jazz	51	B3 Jazz & DX
20	CP-70	52	All Saws
21	Juno 60	53	MegaSynth
22	Brass Section	54	OB & Saws
23	OB Juno	55	Prophet PWM
24	Synth Bass/Lead	56	Pulse Keys
25	Piano Strings	57	Wurly & CP
26	Wurlitzer EP	58	Wurly & Solina
27	B3 3rd Perc	59	B3 888 3rd & All Drawbars Out
28	Pulse Piano	60	TB303 & Clavinet
29	OB-Xa	61	SEM
30	Solina Strings	62	OB, Juno & B3
31	SEM Moog	63	SEM, Moog & OBX
32	TB 303/Rhodes	64	All Saws & Squares

General MIDI Program Chart

Piano		Bass	
1	Piano 1	33	Acoustic Bass
2	Piano 2	34	Fingered Bass
3	Piano 3	35	Picked Bass
4	Honky Tonk	36	Fretless Bass
5	E.Piano 1	37	Slap Bass 1
6	E.Piano 2	38	Slap Bass 2
7	Harpsichord	39	Synth Bass 1
8	Clavinet GM	40	Synth Bass 2
Chromatic Percussion		Strings & Orchestra	
9	Celesta	41	Violin
10	Glockenspiel	42	Viola
11	Music Box	43	Cello
12	Vibraphone	44	Contrabass
13	Marimba	45	Tremolo Strings
14	Xylophone	46	Pizzicato
15	Tubular Bells	47	Harp
16	Dulcimer	48	Timpani
Organ		Ensemble	
17	Organ 1	49	Strings
18	Organ 2	50	Slow Strings
19	Organ 3	51	Synth Strings 1
20	Church Organ	52	Synth Strings 2
21	Reed Organ	53	Choir Aahs
22	Accordion	54	Voice Oohs
23	Harmonica	55	Synth Vox
24	Bandoneon	56	Orchestra Hit
Guitar		Brass	
25	Nylon Guitar	57	Trumpet
26	Steel Guitar	58	Trombone
27	Jazz Guitar	59	Tuba
28	Clean Guitar	60	Mute Trumpet
29	Guitar Mutes	61	French Horns
30	Overdrive Guitar	62	Brass
31	Distortion Guitar	63	Synth Brass 1
32	Guitar Harmonics	64	Synth Brass 2

Reed

65 Soprano Sax
66 Alto Sax
67 Tenor Sax
68 Baritone Sax
69 Oboe
70 English Horn
71 Bassoon
72 Clarinet

Synth Effects

97 Ice Rain
98 Soundtrack
99 Crystal
100 Atmosphere
101 Brightness
102 Goblin
103 Echo Drops
104 Star Theme

Pipe

73 Piccolo
74 Flute
75 Recorder
76 Pan Flute
77 Bottle Chiff
78 Shakuhachi
79 Whistle
80 Ocarina

Ethnic

105 Sitar
106 Banjo
107 Shamisen
108 Koto
109 Kalimba
110 Bagpipe
111 Fiddle
112 Shenai

Synth Lead

81 Square Wave
82 Saw Wave
83 Synth Calliope
84 Chiffer Lead
85 Charang
86 Solo Vox
87 5th Saw Wave
88 Bass & Lead

Percussive

113 Tinker Bell
114 Agogo
115 Steel Drum
116 Wood Block
117 Taiko Drum
118 Melodic Tom
119 Synth Drum
120 Reverse Cymbal

Synth Pad

89 Fantasia
90 Warm Pad
91 Poly Synth
92 Space Voice
93 Bowed Glass
94 Metal Pad
95 Halo Pad
96 Sweep Pad

Sound Effects

121 Fret Noise
122 Breath Noise
123 Seashore
124 Bird
125 Telephone
126 Helicopter
127 Applause
128 Gun Shot

General MIDI - Channel 10 Percussion

Select MIDI channel 10 from either bank. There are 8 GM Drum Kits.

Program	Drum Kit	Program	Drum Kit
1	Standard Kit	26	TR-808 Set
9	Room Set	33	Jazz Set
17	Power Set	41	Brush Set
25	Electronic Set	49	Orchestra Set

► **To Select a Specific Drum Kit:**

1. Use the **Select** button to select MIDI Chn.
2. Use the data slider to select **MIDI channel 10**.
3. Select one of the Program Numbers shown in the table above using the preset row/column buttons to select the kit. *OR . . .*
4. Press the **Select** button repeatedly until the **Program LED** is lit, then use the data slider/octave buttons to select the desired drum kit.

General MIDI Drum Map

(Applicable to Kits 1, 9, 17, 25, 26, 33)

Key No.	Sound	Key No.	Sound
35	Acoustic Bass Drum	59	Ride Cymbal 2
36	Bass Drum 1	60	Hi Bongo
37	Side Stick	61	Low Bongo
38	Acoustic Snare	62	Hi Conga Mute
39	Hand Clap	63	Hi Conga Slap
40	Electric Snare	64	Low Conga
41	Low Floor Tom	65	High Timbale
42	Closed Hi-Hat	66	Low Timbale
43	High Floor Tom	67	High Agogo
44	Hi-Hat Pedal	68	Low Agogo
45	Low Tom	69	Cabasa
46	Open Hi-Hat	70	Maracas
47	Low Mid Tom	71	Short Whistle
48	Hi-Mid Tom	72	Long Whistle
49	Crash Cymbal 1	73	Short Guiro
50	High Tom	74	Long Guiro
51	Ride Cymbal 1	75	Claves
52	China Cymbal	76	Hi Wood Block
53	Ride Bell	77	Low Wood Block
54	Tamborine	78	Cuica Mute
55	Splash Cymbal	79	Cuica Open
56	Cowbell	80	Triangle Mute
57	Crash Cymbal 2	81	Triangle Open
58	Vibraslap		

SPECIFICATIONS

General

- Audio Channels: 128
- Data Encoding: 16-bit linear
- Sample Playback Rate: 44.1kHz

Connectivity

- Audio Line Out: Left & Right 1/4" jacks
- Headphone Output: (2) stereo 1/4" jacks
- Footswitch
- Controller Pedal Input
- MIDI In, MIDI Out
- USB-1 Port

Power Requirements

- Supply Voltage: 5VDC +/- 5%
- Current: 1 Ampere
- Power: 5 Watts

PIPELINE Radio Frequency (RF)

- Operating RF range: 2400 - 2483.5 MHz
- Number of RF channels: 3
- RF transmitter power output: 16 dBm (typical)

SAFETY INFORMATION

Refer to the following information to use your product safely, and to reduce the chance of electric shock, short-circuiting, damage, fire, hearing impairment or other hazards. Improper handling may void the warranty for your product. **For more information, read the warranty available with your product.**

- Do not dismantle or attempt to repair your product.
Refer all servicing to authorized repair agents.
- Do not expose your product to temperatures outside the range of 0°C to 40°C (32°F to 104°F).
- Do not pierce, crush or set fire to your product.
- Keep your product away from strong magnetic objects.
- Do not subject your product to excessive force or impact.
- Do not expose your product to water or moisture. Take care not to immerse your product in water or expose it to rain.

Earphones

- When a conductive apparatus, such as earphones, is used in close proximity with a CRT television or CRT monitor, the latter may emit an electrostatic discharge. The electrostatic discharge can be felt as a static shock. While this static shock is usually harmless, it is good practice to avoid close contact with CRT devices when using earphones.
- Do not listen to audio on your earbuds or headphones at high volume for prolonged periods of time as hearing loss may result. For users in the United States, go to www.hei.org for more information.

Removable Battery

- The battery must be recycled or disposed of properly. Contact local agencies for recycling and disposal information.
- Do not allow metal objects to touch the terminals of your battery.
- If there is a leakage, an offensive odor, discoloration, or deformation during charging or use, remove the battery and do not use it again. Clean your hands well before touching food or sensitive areas, for example, your eyes.
- Do not expose to excessive heat such as sunshine, fire or the like.

Wireless Device

- Switch off the device where it is prohibited, or when its use may cause danger or interference such as inside an aircraft, hospitals, or near refuelling points.

Service

- For product service information, go to www.emu.com.

REGULATORY INFORMATION

Notice for the USA

FCC Part 15: This equipment has been tested and found to comply with the limits for a Class B digital device, pursuant to Part 15 of the FCC Rules. These limits are designed to provide reasonable protection against harmful interference in a residential installation.

This equipment generates, uses and can radiate radio frequency energy and, if not installed and used in accordance with instructions, may cause harmful interference to radio communications. However, there is no guarantee that interference will not occur in a particular installation. If this equipment does cause harmful interference to radio or television reception, which can be determined by turning the equipment off and on, the user is encouraged to try to correct the interference by one or more of the following measures:

- Reorient or relocate the receiving antenna.
- Increase the separation between the equipment and receiver.
- Connect the equipment into an outlet on a circuit different from that to which the receiver is connected.
- Consult the dealer or an experienced radio/TV technician for help.

This device complies with part 15 of the FCC Rules. Operation is subject to the following two conditions:

1. This device may not cause harmful interference, and
2. This device must accept any interference received, including interference that may cause undesired operation.

CAUTION: To comply with the limits of the Class B digital device, pursuant to Part 15 of the FCC Rules, this device must be installed with computer equipment certified to comply with Class B limits. All cables used to connect to the computer and peripherals must be shielded and grounded. Operation with non-certified computers or non-shielded cables may result in interference to radio or television reception.

MODIFICATION: Any changes or modifications not expressly approved by the grantee of this device could void the user's authority to operate the device.

WARNING: To satisfy FCC RF exposure requirements for mobile transmitting devices, a separation distance of 20 cm or more should be maintained between the antenna of this device and persons during device operation.

To ensure compliance, operations at closer than this distance is not recommended. The antenna used for this transmitter must not be co-located in conjunction with any other antenna or transmitter.

California Proposition 65 Statement

WARNING: Handling this product may expose you to chemicals known to the State of California to cause cancer and birth defects or other reproductive harm.

Wash hands after handling.

Explanatory Note: California Safe Drinking Water and Toxic Enforcement Act of 1986 (Proposition 65) requires special product labeling for products containing certain chemicals known to the State of California to cause cancer, birth defects or other reproductive harm. Creative has chosen to provide a warning based on its knowledge about the presence of one or more listed chemicals without attempting to evaluate the level of exposure. With Creative's products, the exposure may be below the Proposition 65 level of concern, or could even be zero. However, out of an abundance of caution, Creative has elected to place the Proposition 65 warning on its products.

Déclaration de la Proposition 65 de la Californie

AVERTISSEMENT: La manipulation de ce produit peut vous exposer à des produits chimiques qui sont reconnus par l'État de la Californie comme pouvant provoquer le cancer, des anomalies congénitales ou d'autres effets nuisibles à la reproduction.

Veuillez vous laver les mains après l'avoir manipuler.

Note explicative: La Proposition 65 (California Safe Drinking Water and Toxic Enforcement Act of 1986) de la Californie sur les matières dangereuses et l'eau potable exige un étiquetage spécial pour les produits contenant certains produits chimiques qui sont reconnus par l'État de la Californie comme pouvant provoquer le cancer, des anomalies congénitales ou d'autres effets nuisibles à la reproduction. Creative a choisi d'inclure une mise en garde s'appuyant sur sa connaissance de la présence d'un ou de plusieurs de ces produits chimiques sans essayer d'en évaluer le niveau d'exposition. Pour les produits de Creative, le niveau d'exposition peut être inférieur au niveau critique établi par la Proposition 65 ou même être nul. Néanmoins, par souci extrême de prudence, Creative a choisi de placer l'avertissement de la Proposition 65 sur ses produits.

Notice for Canada

This Class B digital apparatus complies with Canadian ICES-003. Cet appareil numérique de la classe B est conforme à la norme NMB-003 du Canada.

Son Fonctionnement est sournis aux deux conditions suivantes :

1. Le matériel ne peut être source D'interférences et.
2. Doit accepter toutes les interférences reques,Y compris celles pouvant provoquer un fonctionnement indésirable.

CANADIAN CLASS B STATEMENT: This digital device does not exceed the Class B limits for radio noise emissions from digital apparatus as set out in the interference-causing equipment standard entitled "Digital Apparatus," ICES-003 of the Department of Communications. Cet appareil numérique respecte les limites de bruits radioélectriques applicables aux appareils numériques de Class B prescrites dans la norme sur le matériel brouilleur. "Appareils

Numeriques,” NMB-003 edictee par le ministre des Communications.

MODIFICATION: Any changes or modifications not expressly approved by the grantee of this device could void the user’s authority to operate the device. Toute modification non approuvée explicitement par le fournisseur de licence de l’appareil peut entraîner l’annulation du droit de l’utilisateur à utiliser l’appareil.

European Compliance

This product conforms to the following: EMC Directive 2004/108/EC.

Mains operated products for the European market comply with Low Voltage Directive 2006/95/EC.

Communication / RF wireless products for the European market comply with R&TTE Directive 1999/5/EC.

CAUTION: To comply with the Europe CE requirement, this device must be installed with CE certified computer equipment which meet with Class B limits. All cables used to connect this device must be shielded, grounded and no longer than 3m in length. Operation with non-certified computers or incorrect cables may result in interference to other devices or undesired effects to the product.

MODIFICATION: Any changes or modifications not expressly approved by Creative Technology Limited or one of its affiliated companies could void the user’s warranty and guarantee rights.

WEEE Directive 2006/66/EC

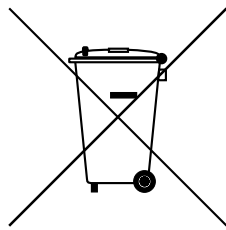

FOR REMOVABLE BATTERY (Li-ion/polymer, button/coin cells, cylindrical cells)

This product (PIPEline) contains one or more of the above removable batteries. The crossed-out wheeled bin symbol indicates that the battery in this product should not be treated as unsorted municipal waste upon reaching its end of life. Instead it should be taken to separate collection and recycling schemes.

Batteries containing heavy metal content will have a two-letter symbol for the chemical under the crossed-out wheeled bin symbol. ‘Cd’ stands for cadmium, ‘Pb’ for lead, and ‘Hg’ for mercury. You can help the environment and avoid public health hazards by recycling the battery at an authorized recycling facility or the place of purchase. To find the nearest authorized recycling center, contact your local authority. Instructions for removing the battery can be found in the product user manual. The instructions should be followed carefully before attempting to remove the battery.

FOR INTEGRATED BATTERY

This product contains Lithium ion/polymer battery that should only be removed by an authorized recycling center. By recycling this product at your local authorized recycling center, or the place of purchase, the battery will be removed and recycled separately.

WEEE Directive 2002/96/EC

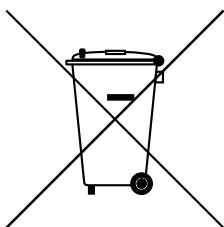

The use of the WEEE Symbol indicates that this product may not be treated as household waste. By ensuring this product is disposed of correctly, you will help protect the environment. For more detailed information about the recycling of this product, please contact your local authority, your household waste disposal service provider or the shop where you purchased the product.